

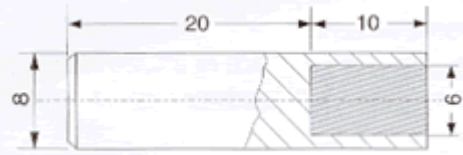



**DIAMOND GRIT IMPREGNATED (THREAD DRESSERS):**

Diamond Grit Impregnated Thread Dressers are used for finish grinding i.e. on screw thread, gear & profile grinding machines as well as on tool & plain grinder.

- Light dressing force
- Acute angled wheel profile can be maintained.
- Effective open structure of grinding wheel is maintained.

Catalogue No.		Diamond Size in Micron	Dimensions in MM
86	F	160	
	F F	100	
	F F F	75	
64	F	160	
	F F	100	
	F F F	75	
H= Tungsten Carbide Bond. W= Tungsten Bond			

**Holders for diamond grit impregnated:**

Cylindrical Holder	
Cylindrical Holder	

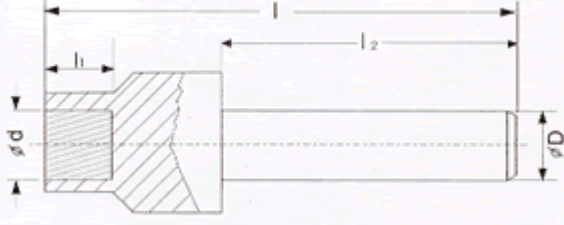
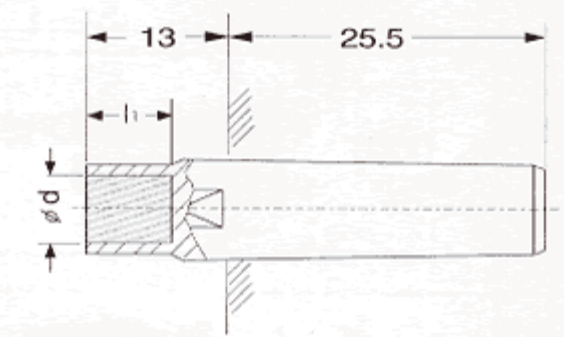
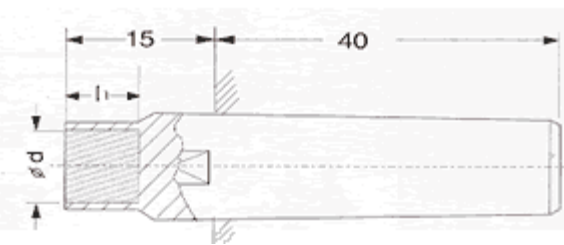
<p>Cylindrical Holder with Head</p>	
<p>Morse taper 0</p>	
<p>Morse taper 1</p>	

**STAR DIAMOND TOOLS**  
12, Ujagar Industrial Estate, W. T. Patil Marg, Deonar,  
Mumbai - 400 088. INDIA.  
Tel.: +91-22-2556 7501/ 6797 8172  
Fax: + 91-22-2550 2277/ 6797 8171  
Email: [stardia@gmail.com](mailto:stardia@gmail.com) Website: [www.stardia.com](http://www.stardia.com)

**star**  
Diamond Tools

**star**  
Diamond Tools