

MICROBORE TOOLS:

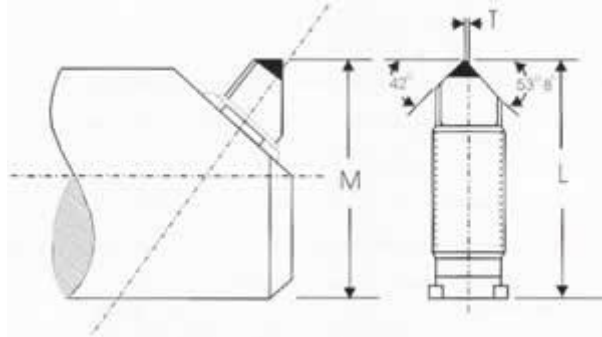

T= Tool Point Offset is on the Right of centre of cartridge

Note: * All dimension in mm, * 12° top rake can be used Aluminium. * All specifications subject to change without notice. * All left cartridges will have same tool Geometry. * Ordering please specify PCD or CBN

Microbore No.	M. Min Bore	Length	T
M1 A2	16.1	14.2	0.4
M1 B2	13.4	11.4	0.4
M2 A2	21.1	19.9	0.4
M2 B2	18.8	16.8	0.4
M3 A2	26.1	25.5	0.8
M3 B2	23.1	21.5	0.8
M5 A2	41.4	39.8	1.2
M5 B2	35.8	33.4	1.2
M7 A2	58.8	55.7	1.6
M7 B2	53.3	49.3	1.6

STAR DIAMOND TOOLS

12, Ujagar Industrial Estate, W. T. Patil Marg, Deonar,
Mumbai - 400 088. INDIA.

Tel.: +91-22-2556 7501/ 6797 8172

Fax: + 91-22-2550 2277/ 6797 8171

Email: stardia@gmail.com Website: www.stardia.com

